

SOLLEVATORE A 4 COLONNE 4 POST LIFT

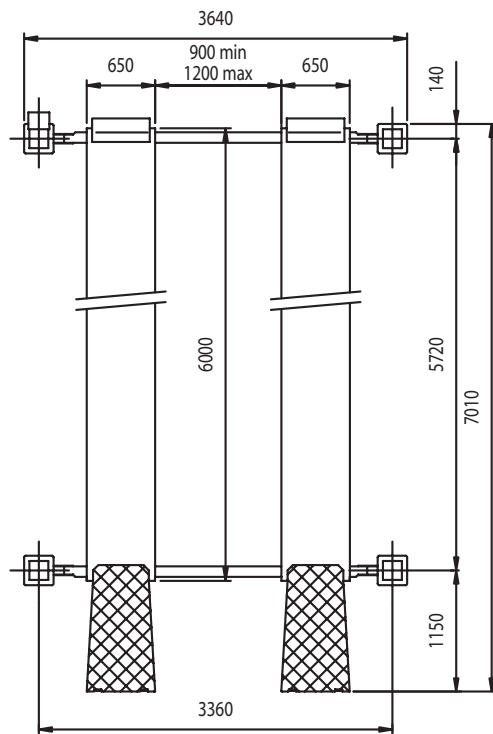
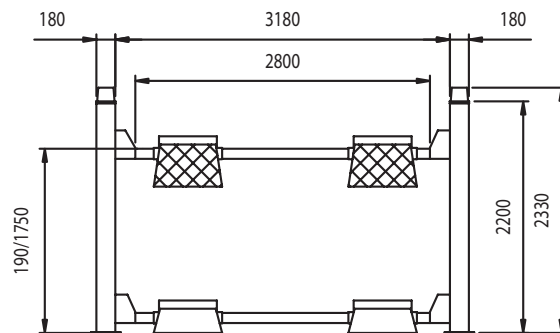

528 Sollevatore elettroidraulico a 4 colonne

Pont élévateur électrohydraulique 4 colonnes
Electro-hydraulic 4 post-lift
Elektrohydraulische 4-Säulen Hebebühne

- Sicurezza in caso di rottura fune
- Sicurezza idraulica in caso di sovraccarico
- Valvola di controllo velocità discesa
- Valvola sicurezza in caso di rottura tubo idraulico
- Comandi uomo presente 24V
- Comando sgancio elettrico
- Comando automatico di discesa
- Insonorizzazione sicurezze
- Avvisatore acustico fase finale discesa
- Sécurité en cas de rupture du câble
- Sécurité hydraulique en cas de surcharge
- Vanne de contrôle descente
- Vanne de sécurité hydraulique en cas de rupture de tuyauterie
- Commande de type "homme mort" 24V
- Déverrouillage à commande électrique
- Commande automatique de descente
- Insonorisation des sécurités
- Avertisseur acoustique phase finale descente
- Safety device in case of rope breaking
- Overload safety-device
- Descent control valve
- Safety-valve in case of sudden loss of pressure
- "Dead man" controls 24V
- Electrical controlled fall safety
- Automatic descent control
- Soundproof safety devices
- Acoustic warning final descent phase
- Feststellvorrichtung in fall von Seilabbruch
- UL-Sicherheitsventil
- Absenk-Kontroll-Ventil
- SB-Sicherheitsentil
- Totmannknopf-Schaltung 24V
- Elektrische Auslösung der Sicherheitsarretierung
- Automatische Absenksteuerung
- Sehr laufruhig durch elektrische Verriegelung
- Akustisches Signal Endphase Abstieg



DATI TECNICI	DONNEES TECHNIQUES	TECHNICAL DATES	TECHNISCHE DATEN	528	
Portata	Capacité	Capacity	Tragfähigkeit	t	6
Motore trifase	Moteur triphasé	Three-phase motor	3-Phasen-Motor	kw	3
Tensione	Voltage	Voltage	Spannung	V/Hz	230-400/50
Salita	Montée	Lifting	Hubzeit	sec	55
Discesa	Descente	Descent	Absenkzeit	sec	55
Peso	Poids	Weight	Gewicht	kg	1730