

## SOLLEVATORE A 4 COLONNE 4 POST LIFT

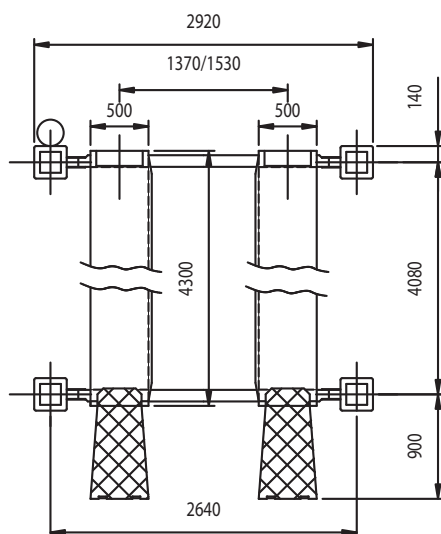

### OPTIONAL V520.1

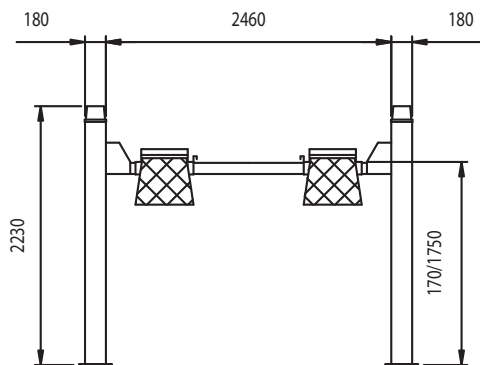
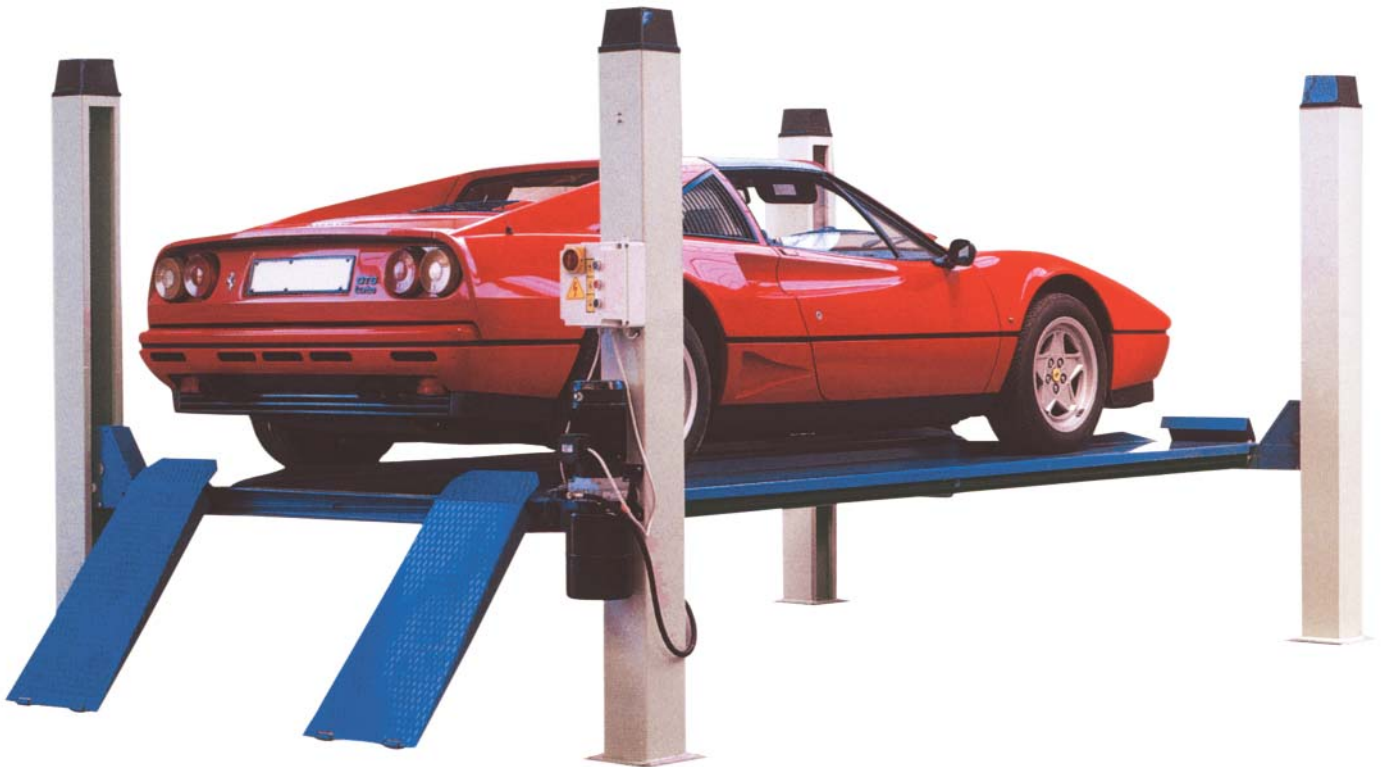

**521** Sollevatore elettroidraulico a 4 colonne a sgancio elettrico  
 Pont élévateur électrohydraulique 4 colonnes avec déverrouillage électrique  
 Electro-hydraulic 4 post-lift with electric release  
 Elektrohydraulische 4-Säulen Hebebühne mit elektrischer Auslösung

- Sicurezza in caso di rottura fune
- Sicurezza idraulica in caso di sovraccarico
- Valvola di controllo velocità discesa
- Valvola sicurezza in caso di rottura tubo idraulico
- Comandi uomo presente 24V
- Comando sgancio elettrico
- Avvisatore acustico fase finale discesa
- Sécurité en cas de rupture du câble
- Sécurité hydraulique en cas de surcharge
- Vanne de contrôle descente
- Vanne de sécurité hydraulique en cas de rupture de tuyauterie
- Commande de type "homme mort" 24V
- Déverrouillage à commande électrique
- Avertisseur acoustique phase finale descente
- Safety device in case of rope breaking
- Overload safety-device
- Descent control valve
- Safety-valve in case of sudden loss of pressure
- "Dead man" controls 24V
- Electrical controlled fall safety
- Acoustic warning final descent phase
- Feststellvorrichtung in fall von Seilabbruch
- UL-Sicherheitsventil
- Absenk-Kontroll-Ventil
- SB-Sicherheitsentil
- Totmannknopf-Schaltung 24V
- Elektrische Auslösung der Sicherheitsarretierung
- Akustisches Signal-Endphase Abstieg



DATI TECNICI	DONNEES TECHNIQUES	TECHNICAL DATES	TECHNISCHE DATEN	521	
Portata	Capacité	Capacity	Tragfähigkeit	t	3.5
Motore trifase	Moteur triphasé	Three-phase motor	3-Phasen-Motor	kw	2.2
Tensione	Voltage	Voltage	Spannung	V/Hz	230-400/50
Salita	Montée	Lifting	Hubzeit	sec	50
Discesa	Descente	Descent	Absenkzeit	sec	45
Peso	Poids	Weight	Gewicht	kg	820